



# Walkways and Terraces on stilted pedestals

## ZinCo-Elefeet.

Some roofs do not have the load-bearing capacity to carry the load of the base layer, bedding material and surface layer. In this instance the ZinCo-Elefeet are able to bear the load, and as a result of its minimal weight, only the weight of

the surface has to be taken into consideration. Surface water can be drained quickly and easily through the open joints and into the lower cavity; in addition, this open subspace provides good aeration. If higher Elefeet are used,

water pipes, cables, or water hoses can be accommodated and used, for example, to irrigate adjacent intensive green areas.



Our range of different Elefeet permit an elevation of the paving from 40 to 230 mm. Even elevations up to 400 mm can be realized by using additional Elefeet Extension Pieces.



Each Elefeet is vertically adjustable by turning the swivel. Even after installation, a single slab can be lifted to adjust the relevant Elefeet.



This project decided on Elefeet to create a water reservoir underneath the surface layer in case of heavy rainfall.



Constructing surfaces on Elefeet is not only restricted to small areas; this picture shows a Beer Garden which is also built on Elefeet.

### The installation of Elefeet offers various important benefits:

- Very low weight – only the surface layer needs to be considered.
- Simple, fast and weather independent application; no transport problems (e.g. gravel, mortar) to and within the installation area.
- Continuously vertically adjustable pedestals for build-up heights from ca. 40 to 400 mm.
- Precise levelling with vertical adjustment ring.
- ZinCo accessories allow for greater roof slopes to be levelled out.
- Elefeet Cantilever Arm Support to install edge areas.
- Open joints, free from pollution and weeds.
- Low maintenance and service required.



≥ 80 - ca. 450 mm

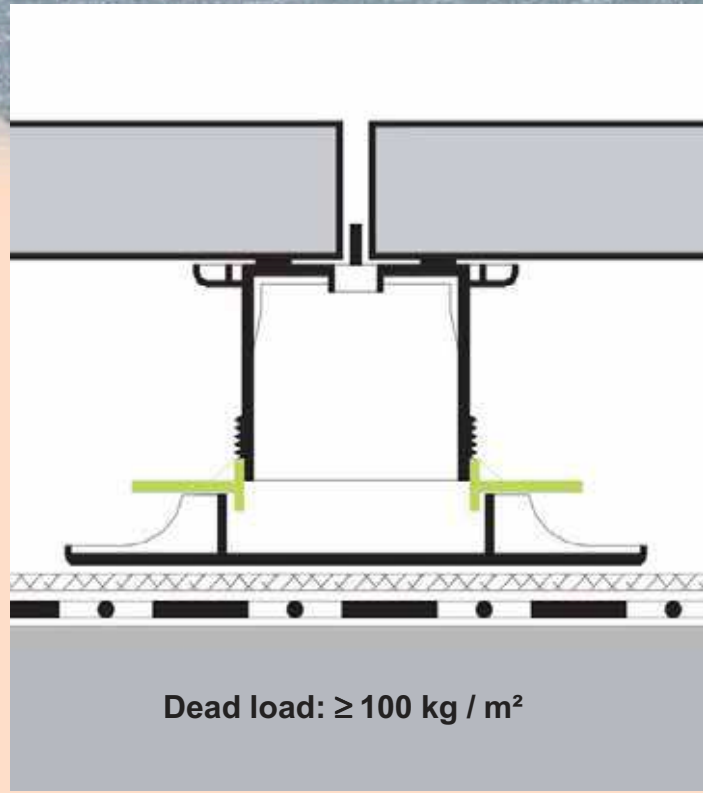

Slabs of concrete, natural stone,  $d \geq 40$  mm or wooden surfaces

**ZinCo Elefeet**  
(in various heights)

Elastosave ES 30  
if necessary, separation layer  
e.g. Slip Sheet TGF 20

Roof construction with waterproofing

**Dead load:  $\geq 100$  kg / m<sup>2</sup>**

- Proper drainage of paved surfaces and roofs.
- Useable on roofs without any slope due to large drainage cavity.
- A dry surface reduces the chance of efflorescence.
- Load bearing capacity up to 500 kg/pc.
- Wooden surfaces are easy to install and to be levelled out.
- Excellent aeration of concrete or wooden surfaces.
- Additional accessories for various applications.
- Hollow space useable for the installation of cables, hoses and other service elements.
- Very good mechanical and thermal protection of waterproofing and shielding of UV radiation.



# Precise in detail – The Elefeet system:

## Accessories and alternative solutions.

### Accessories:



Ordinary stilted pedestals are of less utility when it comes to solutions for corner and edge areas. Alternatively, the Elefeet system offers a wide range of accessories for various applications: The protection of waterproofing is ensured by the specially designed Elastosave mat (1). The Cantilever Arm Support (2) allows for close connection to doors or insulating fillets. The doorstop height can be reduced to a



minimum of 50 mm, if a grill (3) is used in front. Alternative sizes are available for grills and cantilever arm support. In addition, vertically adjustable elements

(4) allow continuously adjusting up to 400 mm. For non rectangular paving edges, the Mitre Cut Support (5) could be used.



### Elastoring: The fix alternative

If there is the requirement for a drainage profile while only a low build-up height exists, Elastoring is recommended. The height varies between 5, 10, 15 and 20 mm. With the adjustment ring unevenness can be corrected; this can



be done by cutting or folding the spacer and applied at individual support points. There are special requirements of the substructure for the installation of the Elastoring: any slope showing up in the surface layer is caused by a



sloped substructure and it is difficult to equalize; therefore, the substructure must be levelled. Also, the substructure must have a sufficient load bearing capacity.





Elefeet can be used for different surfaces such as the combination of concrete slabs and terrace grills. Another variation

is the application of a wooden surface. The desired slope for the system build up can be created with the elevated

space for a green roof application. This surface rise from the threshold towards the perimeter to get sufficient

**This example demonstrates the quantity calculation of Elefeet or Elastoring pieces:**

**Terrace area: 5.0 x 10.0 m**

**Concrete slab: 400 x 400 mm**

Lengthwise:  $(10.00 / 0.40) + 1 = 25 + 1 = 26$

Crosswise:  $(5.00 / 0.40) + 1 = 12.5 + 1 = 14$

**Number of Elefeet: 26 x 14 = 364 pieces**

The amount of pieces required is much lower on bigger areas due to less edge areas; whereas, smaller or geometrical unsteady areas need a much higher amount.

For pavers with 400 x 400 mm: 7.3 pieces/sqm required

For pavers with 500 x 500 mm: 4.6 pieces/sqm required

For grids with 600 x 600 mm: 3.1 pieces/sqm required (see wooden paving above)